



CWE Store Fixtures



Product Guide

Gondola Retail Shelving



Multi functional, easily adjustable shelving system in both wall and island applications.

- A: UPRIGHT POST
- B: BACK PANELS
- C: RAILS (Top, Center, Bottom)
- D: BASE BRACKETS
- E: BASE FRONT
- F: BASE DECKS
- G: UPRIGHT POST END TRIM
- H: BASE END TRIM
- I: SHELF

For add ons, you will not require parts as listed:

- 1-A Upright Post
- 2-G Upright Post End Trim
- 2-D Base Brackets
- 1 Pair-H Base End Trim

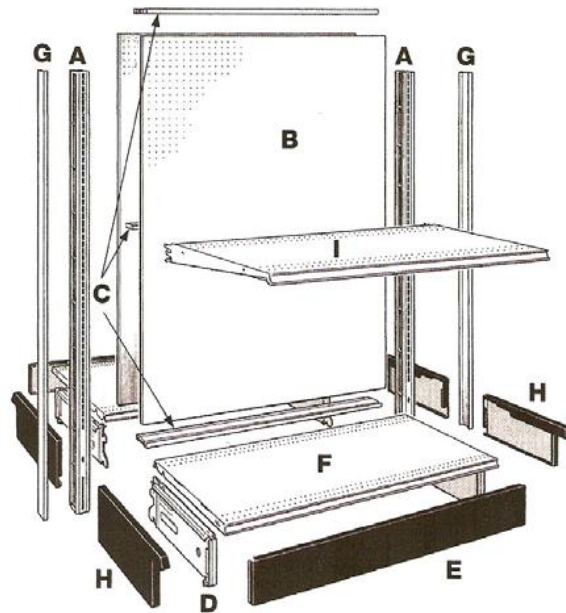

Free Standing Wall End Displays Pegboard front and back panels Uniformly distributed load of Deck 600 lb. 13" 16" 19" and 22" Other back panel styles are available Order Shelves separately Order Gap Filler to close o bottom rear when the unit is wider than the island width Actual width of unit equals the nominal width plus 2" Base End Trim and Closed Base Front in Black Only

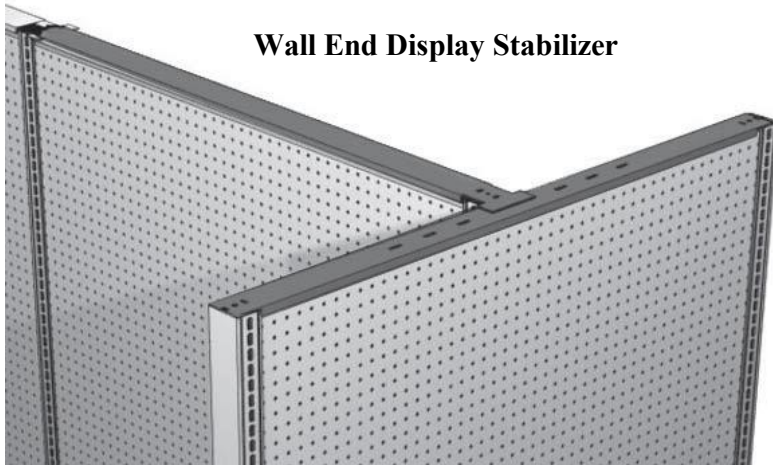

Wall End Display Stabilizer

Wall End Stabilizer with Base Anchors Freestanding 30" 36" and 48" wall end display to a 36" or 48" Island Section Wall End and Gondola End Section Top Rail not required

Wall End Display Bracket Attaches freestanding Wall End Display to same height or taller Gondolas Maintains End Display position Restricts movement from shopping carts or floor scrubbers

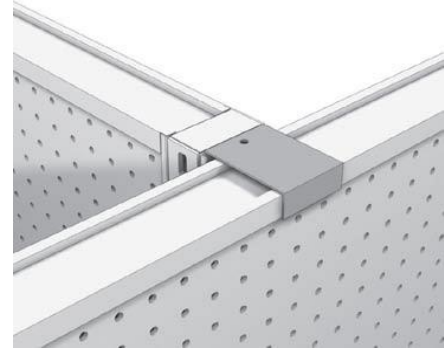

No Base Wall End Display Wall end display used without a Base Deck. Includes Upper and Lower Stabilizer (required to attach adjoining Island Section) Attaches to an equal height International Gondola Unit Includes Pegboard front and back panels Other panel styles are available Order rear gap filler separately when unit is wider than the island Order shelves separately Compatible with both 06 and low base

NOTE: All No Base Wall End Units intended for use with helves, peg hooks, or slatwalls accessories must include a floor display to direct traffic away from protrusions. Extension Uprights can not be used on this display. Wall End Stabilizer with Base Anchors Freestanding

Specialty Display 4 Way Display / Service and Display Counter Tops



4 Way Gondola 54" H 13" Deck 48" Square w/
12 - 13x36 inch Shelves



A

C



B



Service and Display Counters

A - Base deck 13" 16" 19"

A- Counter Top 17" 20" 23"

B- Base Deck 13" -13" / 13" - 16" / 16"-16"

B- Counter Top 32" 35" 38"

C- Base Deck 13"-13" / 13" -16" / 16"-16"

C- Counter Top 30" 33" 36"

UPRIGHT POST

For Wall and Island sections, Slotted 1" on center Platinum, Silver Grey, White

PLATINUM/WHITE/GREY

URP-36/G	36"	9.2 lb
URP-48/G	48"	11.8 lb
URP-54/G	54"	12.9 lb
URP-60/G	60"	14.2 lb
URP-66/G	66"	15.9 lb
URP-72/G	72"	17.2 lb
URP-84/G	84"	19.7 lb
URP-96/G	96"	22.5 lb

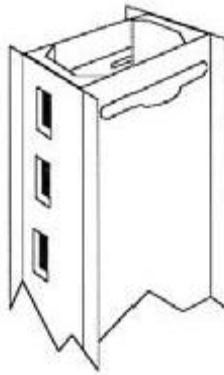

UPRIGHT POST END TRIM

Use to finish off end of section. Fits easily onto upright Platinum, Silver/Grey, or White finish.

PLATINUM/WHITE/GREY

URPC-36/P	36"	.6 lb
URPC-48/P	48"	.8 lb
URPC-54/P	54"	.9 lb
URPC-60/P	60"	1.0 lb
URPC-66/P	66"	1.2 lb
URPC-72/P	72"	1.3 lb
URPC-84/P	84"	1.4 lb
URPC-96/P	96"	1.6 lb

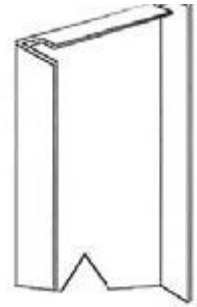

POST CAPS

Use to finish off end of section. Fits easily onto upright Platinum, Silver Grey, or White finish.

PLATINUM/WHITE/GREY

URPCAP/P	0.1 lb
URPCAP/G	0.1 lb
URPCAP/W	0.1 lb

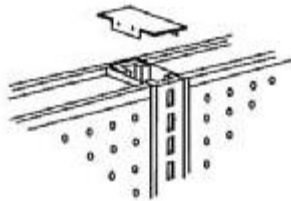

WALL MOUNT STANDARDS

Wall mount standards are available in Platinum, Silver Grey or White finish.

WMST - 96 96"



GONDOLA BASE DECK

Mounts on base bracket to create bottom shelf. Front molding accommodates 1-1/4" tags. Platinum, Silver Grey or White finish.

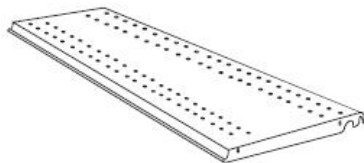

BD 3013 / P	7.0 lb	13" x 30"
BD 313 / P	8.6 lb	13" x 36"
BD 316 / P	9.5 lb	16" x 36"
BD 319 / P	10.7 lb	19" x 36"
BD 322 / P	12.3 lb	22" x 36"
BD 413 / P	11.9 lb	13" x 48"
BD 416 / P	12.9 lb	16" x 48"
BD 419 / P	14.2 lb	19" x 48"
BD 422 / P	16.9 lb	22" x 48"

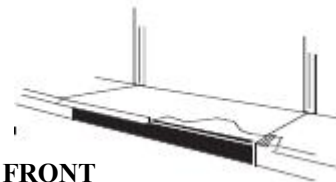

BASE FRONT

Closed, finished appearance. Black finish.

FKP-06-30 / B	30" x 6" Deck	2.2 lb
FKP-06-36 / B	36" x 6" Deck	3.2 lb
FKP-06-48 / B	48" x 6" Deck	4.2 lb

BASE BRACKET

Includes a leveling leg for uneven -



BBS-06-13 / B	13" Deck / Actual Length 10" Bracket
BBS-06-16 / B	16" Deck / Actual Length 13" Bracket
BBS-06-19 / B	19" Deck / Actual Length 16" Bracket
BBS-06-22 / B	22" Deck / Actual Length 19" Bracket

BASE END TRIM

Attaches to edge of base bracket for clean finish. Black finish. Sold in pairs.



BSC-06-13 / B	13" Long	3.4 lb
BSC-06-16 / B	16" Long	3.8 lb
BSC-06-19 / B	19" Long	4.7 lb
BSC-06-22 / B	22" Long	5.7 lb

TOP RAIL

Finishes and supports top of panel. Platinum, Silver Grey and White.

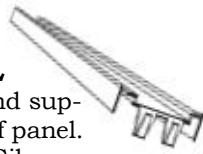

TR-30 P	30"	1.0 lb
TR-36 P	36"	1.4 lb
TR-48 P	48"	1.8 lb

CENTER RAIL

Spaces and supports uprights.

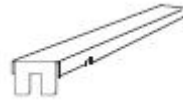

CR-30	30"	1.0 lb
CR-36	36"	1.2 lb
CR-48	48"	1.4 lb

BOTTOM RAIL

Supports bottom of panel. Platinum, Silver/Grey and



LR-30 P	30"	0.6 lb
LR-36 P	36"	1.1 lb
LR-48 P	48"	1.5 lb

HD BOTTOM SLATWALL RAIL

Reinforced to support Slat-wall weight. Platinum, Silver



SWLR-30 P	30"	2.0 lb
SWLR-36 P	36"	2.6 lb
SWLR-48 P	48"	3.3 lb

SPLICER RAIL

Splices two panels together. Platinum, Silver Grey and White.



SP-30 P	30"	1.0 lb
SP-36 P	36"	1.7 lb
SP-48 P	48"	2.4 lb

CENTER SLATWALL RAIL

Spaces and supports uprights of slatwall. Paint Finish



SWCR-30	30"	1.6 lb
SWCR-36	36"	2.1 lb
SWCR-48	48"	2.8 lb

PEGBOARD SHEETS

1/4" diameter hole. 1" on center spacing with equal margins. Available in Platinum, Silver Grey and White.

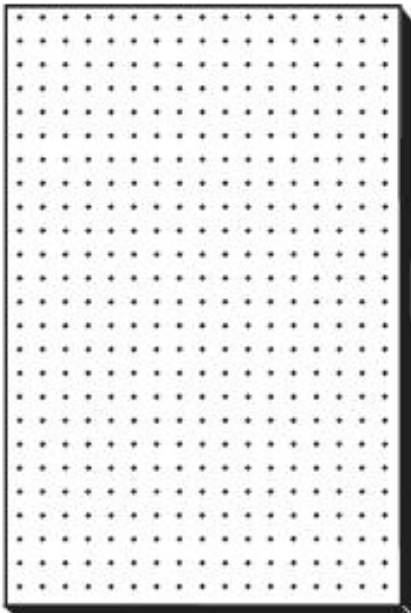

P-3648	34 3/16" x 46 1/2"	12.6 lb.
P-4848	40 3/16" x 46 1/2"	14.3 lb.
P-5448	46 3/16" x 46 1/2"	17.1 lb.
P-6048	52 3/16" x 46 1/2"	19.3 lb.
P-6648	58 3/16" x 46 1/2"	21.4 lb.
P-7248	64 3/16" x 46 1/2"	23.5 lb.
P-8448 (2 pce)	47 3/4" x 46 1/2"	17.1 lb.
P-8448 B	28 5/16" x 46 1/2"	10.5 lb.
P-9648 (2 pce)	47 3/4" x 46 1/2"	17.1 lb.
P-9648 B	40 3/16" x 46 1/2"	15.0 lb.
P-3636	34 3/16" x 34 1/2"	10.0 lb.
P-4836	40 3/16" x 34 1/2"	10.5 lb.
P-5436	46 3/16" x 34 1/2"	12.6 lb.
P-6036	52 3/16" x 34 1/2"	15.9 lb.
P-6636	58 3/16" x 34 1/2"	19.3 lb.
P-7236	64 3/16" x 34 1/2"	19.3 lb.
P-8436 (2 pce)	47 3/4" x 34 1/2"	12.6 lb.
P-8436 B	28 5/16" x 34 1/2"	9.5 lb.
P-9636 (2 pce)	47 3/4" x 34 1/2"	12.6 lb.
P-9636 B	40 3/16" x 34 1/2"	10.0 lb.
P-5430	46 3/16" x 28 1/2"	9.0 lb.
P-7230	64 3/16" x 28 1/2"	17.0 lb.

MARTEK SOLID BOARD

Stock sizes available in Platinum, Silver Grey and White. Other sizes available upon special order.



- M-5436 54" x 36"
- M-5448 54" x 48"

SLATWALL PANELS

Stock colors are Almond, Silver Grey, White, and Hard Rock Maple. Custom finishes available upon request. Slatwall Panels for Gondolas, please refer to peg board sizes.

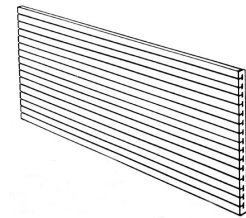

- SW-5448 54" x 48"

CENTER SHELF

Front molding accomodates 1-1/4" tags. Platinum, Silver/Grey or White finish.

- DUS 1330 / P 30" x 13" 6.6 lb
- DUS 310 / P 36" x 10" 6.6 lb
- DUS 313 / P 36" x 13" 8.0 lb
- DUS 315 / P 36" x 15" 8.7 lb
- DUS 317 / P 36" x 17" 10.7 lb
- DUS 319 / P 36" x 19" 11.6 lb
- DUS 322 / P 36" x 22" 12.5 lb
- DUS 410 / P 48" x 10" 9.7 lb
- DUS 413 / P 48" x 13" 10.8 lb
- DUS 415 / P 48" x 15" 11.7 lb
- DUS 417 / P 48" x 17" 13.9 lb
- DUS 419 / P 48" x 19" 14.8 lb
- DUS 422 / P 48" x 22" 19.1 lb

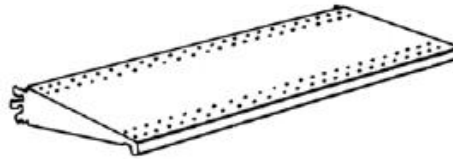

CENTER SHELF FEATURES

SHELVES HAVE 4 WAY ADJUSTABLE BRACKET FOR VARIOUS MERCHANDISE REQUIREMENTS.

Load Capacity:

- 15 degree Up Slope: 300 lb.
- 17 degree Down Slope: 250 lb.
- 30 degree Down Slope: 125 lb.
- Standard Flat Position: 500 lb.

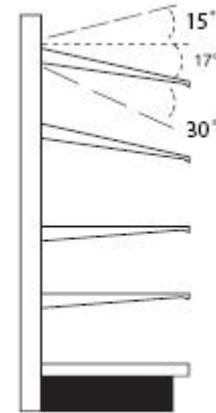

INTERLOCKING WIRE FENCING

Heavy duty steel construction suitable for bulky items. Available in 3" and 5" in heights. Easy snap in installation that interlocks. Chrome finish.

WIRE FRONT

- 348 - BF 3" x 48" 1.2 lb
- 548 - BF 5" x 48" 2.0 lb

WIRE DIVIDER

- 516-BFD 5" x 16" 0.5 lb
- 522-BFD 5" x 22" 0.8 lb

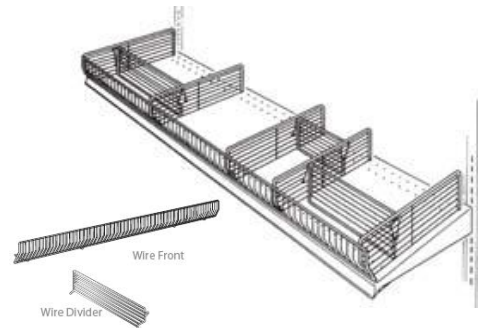

FREESTANDING WIRE FENCING Chrome Finish

Wire Front

- WF - 330 3" x 30" 0.6 lb
- WF - 336 3" x 36" 0.8 lb
- WF - 348 3" x 48" 1.0 lb

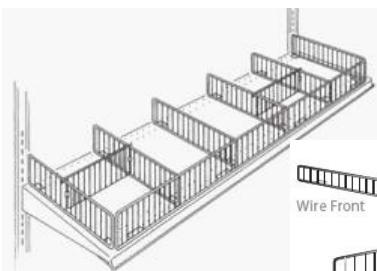

Wire Divider

- WFD - 310 3" x 10" 0.3 lb
- WFD - 313 3" x 13" 0.4 lb
- WFD - 315 3" x 15" 0.6 lb
- WFD - 317 3" x 17" 0.8 lb
- WFD - 319 3" x 19" 1.0 lb

WIRE BASKETS 3" front / 6" back Chrome Finish

WIRE BASKET

- WB-1436 14" x 36" 6.0 lb
- WB-1448 14" x 48" 6.7 lb

WIRE BASKET DIVIDER

- WBD - 14" 6"x 14" 0.5 lb

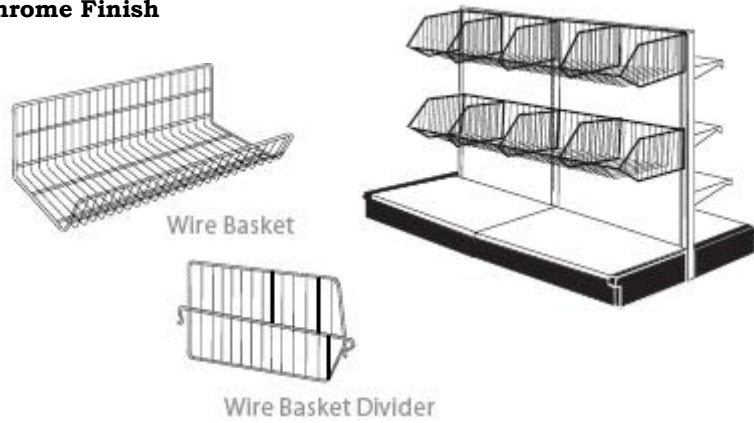

Endless Wire Shelves 3" front / 3"back Chrome Finish

- WS -1448 14" x 48" 7.8 lb

Wire Shelf Dividers

- WSD - 14 (wire divider) 3" x 14" 0.3 lb
- WCD - 4 (cross divider) 3" x 4" 0.1 lb

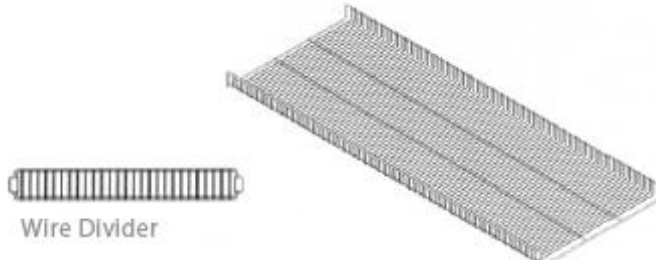

Wire Bracket

- WBBKT 15 / Pairs Wire Bracket 0.5 lb

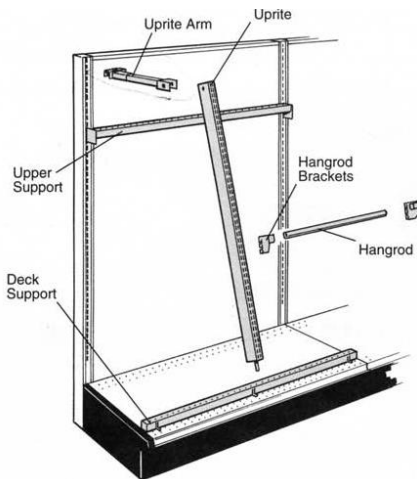
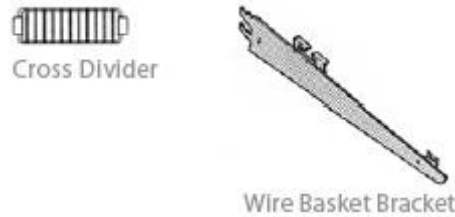

SUPPORT ASSEMBLY

(Consists of (1) each 48" wide Upper Support & Deck Support)

WIDTH	WT.	CAT. NO.	PLT EACH	TIER I EACH	CARTON ^①
48"	6.5	RGDSA48			2

UPRITE ASSEMBLY

(Consists of (1) each Displayer Upright & Upright Arm)

HT.	WT.	CAT. NO.	PLT EACH	TIER I EACH	CARTON ^①
54"	6.0	RGDUA54			2
72"	7.0	RGDUA72			2

① Available in carton package only. Orders will be rounded up to nearest carton quantity as listed above.

HANGROD COMPONENTS

	WIDTH	WT.	CAT. NO.	FINISH	PLT PK4 [Ⓣ]	TIER I PK4 [Ⓣ]
Brackets (Pair)	—	1.0	RDHPK4	PLT		
Hangrod	48"	18.0	RDHPK4	GLV		N/A

Ⓣ Available in packs of 4 only.



Patented Design

№: 119500

Colours Available

Red
Black
Blue



The baskets nest as any traditional hand basket would which does not increase the foot print while at point of entry for the customers.

PRODUCT SPECIFICATIONS:

Weight:	4.5lbs
Stackable:	15 units (recommended)
Height:	42 inches (stacked 15 height)
Length:	24 inches
Width:	13.5 inches

BENEFITS:

- Able to carry over 50% more than traditional hand baskets
- Less space required in the shopping aisles and the express checkouts
- Hands free
- In-store client retention
- Non-skid rubber wheel
- All Swivel Large Castor

With the all swivel large castor the basket can be turned 360 degrees and can move laterally from side to side. This makes this item ideal for narrow aisles and small areas.

